

DIY Beach Bag

Designed by Betsy La Honta



FINISHED SIZE: 11" wide × 13" high × 4" deep

Fabric used is Mosaica by French Bull from Windham Fabrics.

MATERIALS

- 1 roll of vinyl (16" × 1½ yards)
- 1 fat quarter of fabric (18" × 21")
- Optional:* 1" × 20" piece of fast2fuse® MEDIUM or other medium-weight fusible interfacing (handles)

CUTTING

Vinyl:

- 1 piece 16" × 30" (body)
- 1 piece 8" × 10" (pocket)

Fabric:

- 1 strip 1½" × 20" (pocket binding)
- 2 strips 2½" × 20" (tote binding)
- 2 strips 4" × 20" (handles)

VINYL TIPS

- Use a rotary cutter and cutting mat to cut the vinyl instead of using scissors.
- You can use washi tape or masking tape to "mark" your vinyl before sewing. Just test the tape on a vinyl scrap to make sure it doesn't leave any residue.
- Use binder clips (from an office supply store) or quilt binding clips to hold the layers together for sewing. Pins will leave perforations.
- A Teflon sewing machine foot keeps the material moving smoothly through the machine.
- Because vinyl perforates, it is best not to sew back and forth in one place too many times. To secure the stitching at the beginning of a seam, place the presser foot and needle in about ¼", stitch *backward* to the edge, and *then* sew forward along the seamline.

CONSTRUCTION

Seam allowances are ½" unless otherwise noted.

Make the Tote Binding, Handles, and Pocket

1. Sew together the short ends of the 2½" × 20" fabric strips to yield 1 long strip. Press the seam open.
2. Fold the strip of fabric in half lengthwise, wrong sides together. Press. Fold both sides in toward the center crease, fold in half, and press again to yield a ⅝"-wide binding strip.
3. Repeat Step 2 with both 4"-wide fabric strips for the handles to yield 2 pieces 1" × 20". If using fusible interfacing, place it inside one of the first folds and, following the manufacturer's directions, fuse.
4. Topstitch both edges and down the middle of the handle strips.
5. Repeat Step 2 with the 1½"-wide fabric strip to yield 1 piece ⅜" × 20". Cut the strip into 1 piece 8" long and 2 pieces 6" long for the pocket trim.
6. Sandwich an 8" edge of the vinyl pocket piece inside the 8"-long trim piece. Topstitch close to the edge to secure the trim to the pocket.
7. Fold the pocket piece so that the trimmed edge is 1½" below the untrimmed upper edge to form the pocket. Repeat Step 6 to sew a 6" trim piece to each side of the folded pocket, tucking in the bottom raw end of the trim neatly before topstitching. (The upper raw end will be covered up later.)

Make the Tote

1. Fold the vinyl body piece in half, as shown, so that it is 15" × 16". Mark and cut away a rectangle 1½" × 2" from both bottom corners of the folded piece.

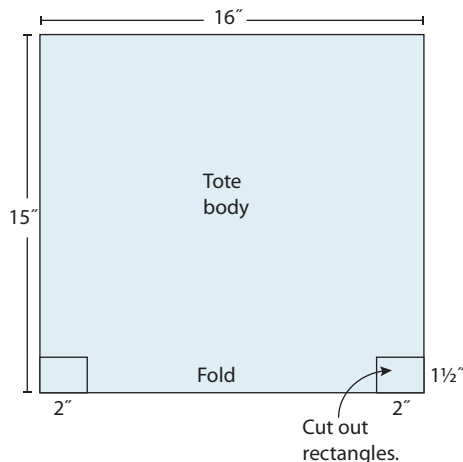

2. Prep the handles by folding each end under ½" and pressing.
3. Open up the folded tote body. Place 1 handle along a 16" edge, as shown, with the raw edges underneath. Make sure the handle is not twisted; then clip in place. Attach the handle to the body by sewing a 1" × 1" square with an X at each end. Repeat this step to attach the remaining handle at the opposite end of the tote body.

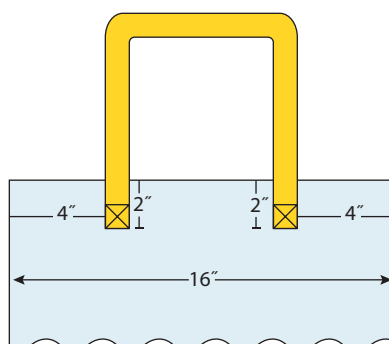

4. Center the upper (open) edge of the pocket on an inside upper edge of the tote body between the handles. Fold the handles back out of the way and baste along the upper edge.
5. Fold the tote in half, right sides together, matching the upper edges and handles. Sew the side seams from the bottom up, with a ½" seam allowance. Trim seam to ¼."
6. Flatten one bottom corner and sew across with a ½" seam. Trim seam to ¼." Repeat on the other corner.

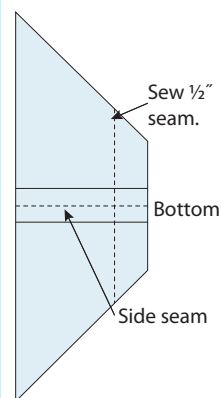

7. Turn the tote right side out. Sandwich the upper edge of the tote inside the ⅝"-wide binding strip. Clip the binding in place all around, finger pressing the side seam allowances open at the top. Overlap the binding ends 1" and trim the excess. Fold ½" of the extra binding to the wrong side. Clip to hold. Topstitch along the lower edge of the binding all around the tote.

We take great care to ensure that the information included in our products is accurate and presented in good faith, but no warranty is provided nor are results guaranteed. Having no control over the choices of materials or procedures used, neither the author nor C&T Publishing, Inc., shall have any liability to any person or entity with respect to any loss or damage caused directly or indirectly by the information contained in or the use of this product. Please be sure to test this product to ensure satisfactory results.